

BLUE STAR

Power Systems Inc.

Diesel Product Line

208-4160 Volt

VD400-02FT4

60 Hz / 1800 RPM

400 kWe / 400 kWe

Standby / Prime

Ratings

	208V	240V	480V	600V	4160V
Phase	3	3	3	3	3
PF	0.8	0.8	0.8	0.8	0.8
Hz	60	60	60	60	60
Generator Model	572RSL6425	572RSL6425	572RSL6425	572RSS4270	573FSM4352
Connection	12 LEAD WYE	12 LEAD DELTA	12 LEAD WYE	4 LEAD WYE	6 LEAD WYE
Standby					
kWe	400	400	400	400	400
AMPS	1390	1204	602	482	69
Temp Rise	105°C / 40°C	105°C / 40°C	105°C / 40°C	105°C / 40°C	105°C / 40°C
Prime					
kWe	400	400	400	400	400
AMPS	1390	1204	602	482	69
Temp Rise	105°C / 40°C	105°C / 40°C	105°C / 40°C	105°C / 40°C	105°C / 40°C

Standard Equipment

- | | | |
|---|---|---|
| <p>Engine</p> <ul style="list-style-type: none"> ▶ Radiator Cooled Unit Mounted (55°C) ▶ Blower Fan & Fan Drive ▶ Starter & Alternator ▶ Oil Pump & Filter ▶ Oil Drain Extension w/Valve ▶ Governor - Electronic Isochronous ▶ 24V Battery System & Cables ▶ SAE Flywheel Housing ▶ Air Cleaner (Dry Single Stage) ▶ Flexible Fuel Connectors ▶ EPA Certified - Tier 4 Final <p>Listing Certifications</p> <ul style="list-style-type: none"> ▶ UL 2200 Listed* ▶ cUL Listed* ▶ CSA Certified* ▶ Seismic Certified to IBC 2018 | <p>Generator</p> <ul style="list-style-type: none"> ▶ Brushless Single Bearing ▶ Automatic Voltage Regulator ▶ ± 0.25% Voltage Regulation ▶ 4 Pole, Rotating Field ▶ 105°C Standby Temperature Rise ▶ 105°C Prime Temperature Rise ▶ 100% of Rated Load - One Step ▶ 5% Maximum Harmonic Content ▶ NEMA MG 1, IEEE and ANSI Standards Compliance for Temperature Rise | <p>Additional</p> <ul style="list-style-type: none"> ▶ Single Source Supplier ▶ Microprocessor Based Digital Control ▶ Interface Connection Box ▶ Control Panel Mounted in NEMA 12 Enclosure ▶ Base - Structural Steel ▶ Main Line Circuit Breaker Mounted & Wired** ▶ SRC Catalyst / Silencer Mounted ▶ Battery Charger 24V 5 Amp ▶ Jacket Water Heater -20°F 5000W 240V w/Isolation Valves ▶ Vibration Isolation Mounts ▶ Radiator Duct Flange (OPU Only) ▶ 2YR / 2000HR Standby Warranty ▶ 1YR / 1500HR Prime Warranty ▶ Standard Colors - White / Gray |
|---|---|---|

*Through 600 VAC

Application Data

Engine			
Manufacturer:	Volvo Penta	Displacement - Cu. In. (lit):	984 (16.1)
Model:	TAD1672VE	Bore - in. (cm) x Stroke - in. (cm):	5.67 (14.4) x 6.50 (16.5)
Type:	4-Cycle	Compression Ratio:	17.0:1
Aspiration:	Turbo Charged, CAC	Rated RPM:	1800
Cylinder Arrangement:	6 Cylinder Inline	Max HP Stby (kWm):	700 (515)

Exhaust System	Standby	Prime
Gas Temp. (Stack): °F (°C)	932 (500)	932 (500)
Gas Volume at Stack Temp: CFM (m³/min)	3,461 (97.9)	3,461 (97.9)
Maximum Allowable Exhaust Restriction (Post SCR Cat.): in. H ₂ O (kPa)	16.0 (4.00)	16.0 (4.00)

Cooling System	Standby	Prime
Ambient Capacity of Radiator: °F (°C)	131 (55.0)	131 (55.0)
Maximum Allowable Static Pressure on Rad. Exhaust: in. H ₂ O (kPa)	0.50 (0.12)	0.50 (0.12)
Water Pump Flow Rate: GPM (lit/min)	108 (409)	108 (409)
Heat Rejection to Coolant: BTUM (kW)	12,113 (212)	12,113 (212)
Heat Rejection to CAC: BTUM (kW)	6,028 (105)	6,028 (105)
Heat Radiated to Ambient: BTUM (kW)	3,415 (59.8)	3,415 (59.8)

Air Requirements	Standby	Prime
Aspirating: CFM (m³/min)	1,324 (37.5)	1,324 (37.5)
Air Flow Required for Rad. Cooled Unit: CFM (m³/min)	18,792 (532)	18,792 (532)
Air Flow Required for Heat Exchanger/Rem. Rad. CFM (m³/min)	Consult Factory For Remote Cooled Applications	

Fuel Consumption	Standby	Prime
At 100% of Power Rating: gal/hr (lit/hr)	26.4 (100)	26.4 (100)
At 75% of Power Rating: gal/hr (lit/hr)	20.3 (77.0)	20.3 (77.0)
At 50% of Power Rating: gal/hr (lit/hr)	14.5 (55.0)	14.5 (55.0)
DEF Consumption (% of fuel consumption)	± 5.90%	± 5.90%

Fluids Capacity	Standby	Prime
Total Oil System: gal (lit)	12.68 (48.0)	12.68 (48.0)
Engine Jacket Water Capacity: gal (lit)	6.30 (23.8)	6.30 (23.8)
System Coolant Capacity: gal (lit)	16.1 (60.9)	16.1 (60.9)
DEF Tank Capacity: gal (lit)	18.5 (70.0)	18.5 (70.0)

Deration Factors

Rated Power is available up to 4,921 Ft (1500m) at ambient temperatures to 122°F (50°C) standby and prime. Consult factory for site conditions above these parameters.

DGC-2020 Control Panel

Standard Features

- ▶ Digital Metering
- ▶ Engine Parameters
- ▶ Generator Protection Functions
- ▶ Engine Protection
- ▶ CAN Bus (J1939) ECU Communications
- ▶ Windows-Based Software
- ▶ Multilingual Capability
- ▶ Remote Communications to RDP-110 Remote Annunciator
- ▶ 16 Programmable Contact Inputs
- ▶ 15 Contact Outputs
- ▶ RS485 Communicator Interface
- ▶ UL Recognized, CSA Certified, CE Approved
- ▶ Event Recording
- ▶ IP 54 Front Panel Rating with Integrated Gasket
- ▶ NFPA 110 Level 1 Compatible

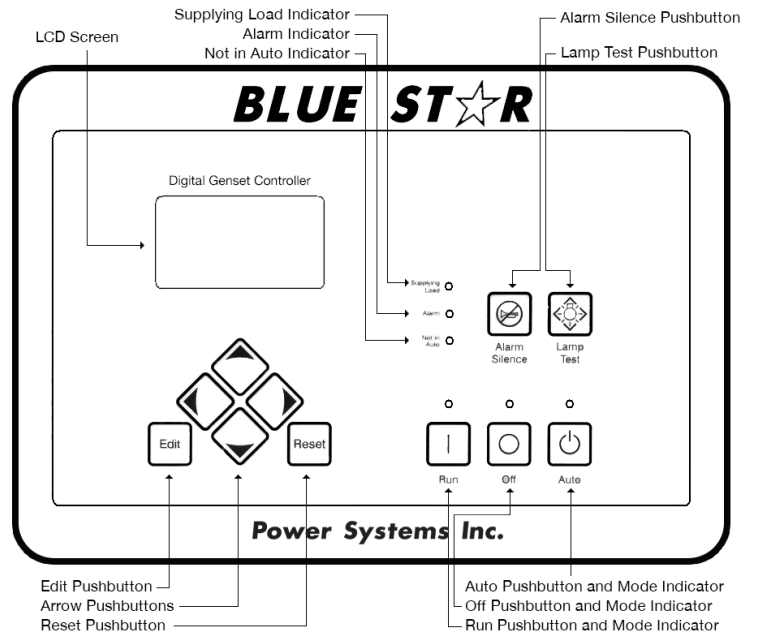

Weights / Dimensions / Sound Data

	L x W x H	Weight lbs
OPU	140 x 72 x 98 in	10,000
Level 1	180 x 72 x 103 in	11,650
Level 2	180 x 72 x 103 in	11,725
Level 3	225 x 72 x 103 in	12,175

Height measured from bottom of base to highest point

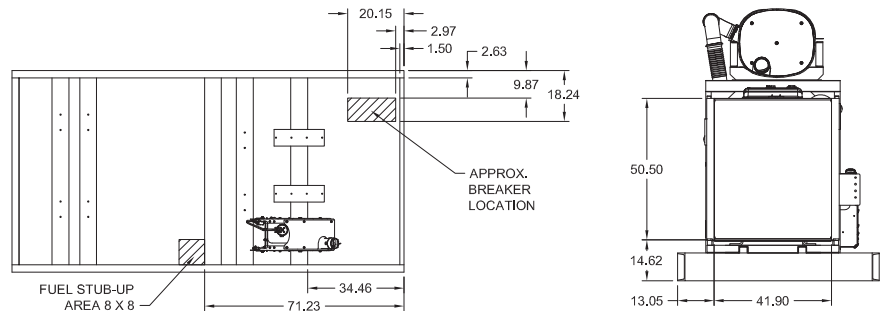

	No Load	Full Load
OPU	86 dBA	88 dBA
Level 1	82 dBA	84 dBA
Level 2	78 dBA	80 dBA
Level 3	72 dBA	74 dBA

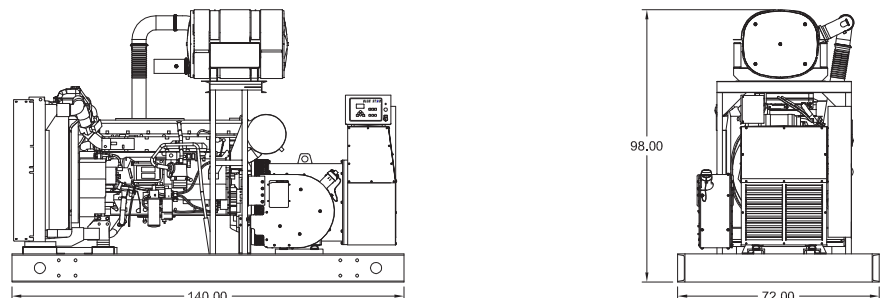

Drawings based on standard open power 480 volt standby generator. Lengths may vary with other voltages. Subject to change without notice. Sound data as measured at 23 feet (7 meters) in accordance with ISO 8528-10 at standby rating.

Diesel Product Line

400 kWe / 400 kWe



Enclosures & Fuel Tanks

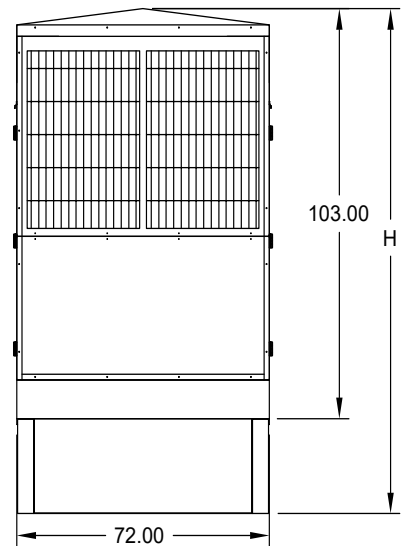
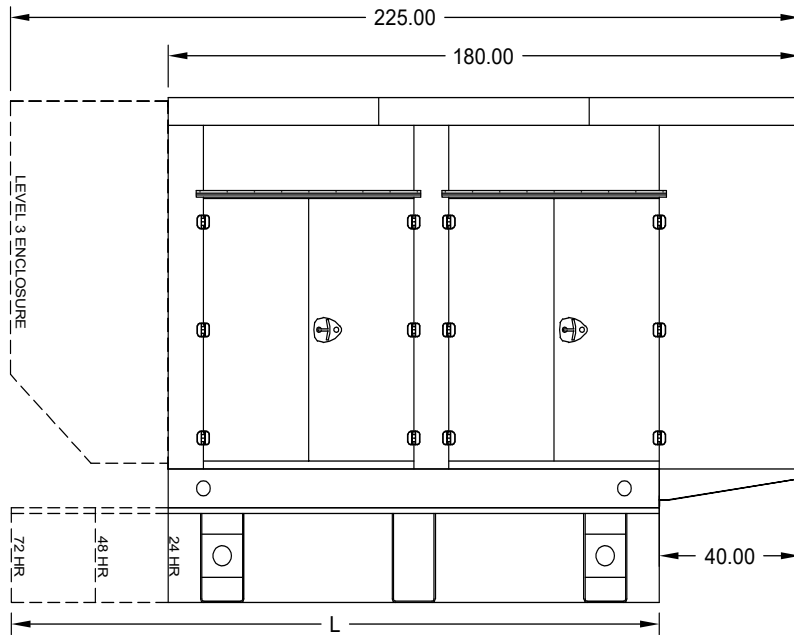

All enclosure models are 200 MPH wind rating certified in accordance with IBC2018 and ASCE/SEI 7-16 standards.

Level 2 & 3 enclosures include sound attenuation foam.

Level 3 enclosure includes frontal sound & exhaust hood.

*Enclosure height does not include exhaust stack.

	24 Hour 710 Gallon	48 Hour 1420 Gallon	72 Hour 2130 Gallon
L	140.00	180.00	250.00
H	127.00	139.00	139.00

All specification sheet dimensions are represented in inches.

All enclosures and fuel tanks are based on the standard standby unit configuration. Any deviation can change dimensions.

Materials and specifications subject to change without notice.

American Owned



American Made

Distributed By:

Blue Star Power Systems, Inc.

2250 Carlson Drive

North Mankato, Minnesota 56003

Phone + 1 507 345 1776

bluestarps.com

quote.bluestarps.com

sales@bluestarps.com