

# BLUE STAR

## Power Systems Inc.

Diesel Product Line

208-480 Volt

VD250-02FT4MP

60 Hz / 1800 RPM

250 kWe / 250 kWe

Standby / Prime

### Ratings

	240V	208V	240V	480V	Multi-Voltage
<b>Phase</b>	1	3	3	3	3
<b>PF</b>	1.0	0.8	0.8	0.8	0.8
<b>Hz</b>	60	60	60	60	60
<b>Generator Model</b>	572RSL6427	432CSL6210	432CSL6210	432CSL6210	432CSL6210
<b>Connection</b>	12 LEAD ZIG-ZAG	12 LEAD WYE	12 LEAD DELTA	12 LEAD WYE	12 LEAD CONFIGURABLE
<b>Standby</b>					
<b>kWe</b>	250	250	250	250	250
<b>AMPS</b>	1042	868	753	376	868/753/376
<b>Temp Rise</b>	105°C / 40°C	105°C / 40°C	105°C / 40°C	105°C / 40°C	105°C / 40°C
<b>Prime</b>					
<b>kWe</b>	250	250	250	250	250
<b>AMPS</b>	1042	868	753	376	868/753/376
<b>Temp Rise</b>	105°C / 40°C	105°C / 40°C	105°C / 40°C	105°C / 40°C	105°C / 40°C

### Standard Equipment

- |   |  |  |
|---|--|--|
| <p><b>Engine</b></p> <ul style="list-style-type: none"> <li>▶ Radiator Cooled Unit Mounted (55°C)</li> <li>▶ Blower Fan &amp; Fan Drive</li> <li>▶ Starter &amp; Alternator</li> <li>▶ Oil Pump &amp; Filter</li> <li>▶ Oil Drain Extension w/Valve</li> <li>▶ Governor - Electronic Isochronous</li> <li>▶ 24V Battery System &amp; Cables</li> <li>▶ Air Cleaner (Dry Single Stage)</li> <li>▶ Flexible Fuel Connector</li> <li>▶ EPA Certified Tier 4 Final</li> </ul> | <p><b>Generator</b></p> <ul style="list-style-type: none"> <li>▶ Brushless Single Bearing</li> <li>▶ Automatic Voltage Regulator</li> <li>▶ ± .25% Voltage Regulation</li> <li>▶ 4 Pole, Rotating Field</li> <li>▶ 105°C Standby Temperature Rise</li> <li>▶ 105°C Prime Temperature Rise</li> <li>▶ 100% of Rated Load - One Step</li> <li>▶ 5% Maximum Harmonic Content</li> <li>▶ NEMA MG 1, IEEE and ANSI Standards Compliance for Temperature Rise</li> </ul> | <p><b>Additional</b></p> <ul style="list-style-type: none"> <li>▶ Single Source Supplier</li> <li>▶ Microprocessor Based Digital Control</li> <li>▶ Control Panel Mounted in NEMA 12 Enclosure</li> <li>▶ Base - Formed Steel</li> <li>▶ Level 3 Enclosure</li> <li>▶ Trailer with Integrated Fuel Tank</li> <li>▶ Main Line Circuit Breaker Mounted &amp; Wired</li> <li>▶ SCR Catalyst / Silencer Mounted</li> <li>▶ Battery Charger 24V 5 Amp</li> <li>▶ Jacket Water Heater -20°F 4000W 240V w/Isolation Valves</li> <li>▶ Vibration Isolation Mounts</li> <li>▶ 2YR / 2000HR Standby Warranty</li> <li>▶ 1YR / 1500HR Prime Warranty</li> <li>▶ Standard Color - White</li> </ul> |
|---|--|--|

## Application Data

<b>Engine</b>			
Manufacturer:	Volvo Penta	Displacement - Cu. In. (lit):	780 (12.8)
Model:	TAD1371VE	Bore - in. (cm) x Stroke - in. (cm):	5.16 (13.1) x 6.22 (15.8)
Type:	4-Cycle	Compression Ratio:	17.8:1
Aspiration:	Turbo Charged, CAC	Rated RPM:	1800
Cylinder Arrangement:	6 Cylinder Inline	Max HP Stby (kWm):	388 (285)

<b>Exhaust System</b>	<b>Standby</b>	<b>Prime</b>
Gas Temp. (Stack): °F (°C)	725 (385)	725 (385)
Gas Volume at Stack Temp: CFM (m³/min)	1,872 (53.0)	1,872 (53.0)
Maximum Allowable Exhaust Restriction (Post SCR Cat.): in. H <sub>2</sub> O (kPa)	32.0 (8.00)	32.0 (8.00)

<b>Cooling System</b>			
Ambient Capacity of Radiator: °F (°C)	131 (55.0)	131 (55.0)	
Maximum Allowable Static Pressure on Rad. Exhaust: in. H <sub>2</sub> O (kPa)	0.50 (0.12)	0.50 (0.12)	
Water Pump Flow Rate: GPM (lit/min)	90.6 (343)	90.6 (343)	
Heat Rejection to Coolant: BTUM (kW)	7,677 (103)	7,677 (103)	
Heat Rejection to CAC: BTUM (kW)	3,526 (62.0)	3,526 (62.0)	
Heat Radiated to Ambient: BTUM (kW)	2,312 (40.5)	2,312 (40.5)	

<b>Air Requirements</b>			
Aspirating: CFM (m³/min)	918 (26.0)	918 (26.0)	
Air Flow Required for Rad. Cooled Unit: CFM (m³/min)	14,196 (402)	14,196 (402)	
Air Flow Required for Heat Exchanger/Rem. Rad. CFM (m³/min)	Consult Factory For Remote Cooled Applications		

<b>Fuel Consumption</b>			
At 100% of Power Rating: gal/hr (lit/hr)	18.7 (70.7)	17.3 (65.3)	
At 75% of Power Rating: gal/hr (lit/hr)	14.3 (54.0)	13.2 (49.8)	
At 50% of Power Rating: gal/hr (lit/hr)	9.71 (36.8)	9.19 (34.8)	
DEF Consumption (% of fuel consumption)	± 6.00%	± 6.00%	

<b>Fluids Capacity</b>			
Total Oil System: gal (lit)	9.50 (36.0)	9.50 (36.0)	
Engine Jacket Water Capacity: gal (lit)	5.28 (20.0)	5.28 (20.0)	
System Coolant Capacity: gal (lit)	6.34 (24.0)	6.34 (24.0)	

### Deration Factors

Rated Power is available up to 4,921 Ft (1500m) at ambient temperatures to 122°F (50°C) standby and prime. Consult factory for site conditions above these parameters.

## DGC-2020 Control Panel

### Standard Features

- ▶ Digital Metering
- ▶ Engine Parameters
- ▶ Generator Protection Functions
- ▶ Engine Protection
- ▶ CAN Bus ECU Communications
- ▶ Windows-Based Software
- ▶ Multilingual Capability
- ▶ Remote Communications to RDP-110 Remote Annunciator
- ▶ 16 Programmable Contact Inputs
- ▶ Up to 15 Contact Outputs (7 standard)
- ▶ UL Recognized, CSA Certified, CE Approved
- ▶ Event Recording
- ▶ IP 54 Front Panel Rating with Integrated Gasket
- ▶ NFPA 110 Level 1 Compatible

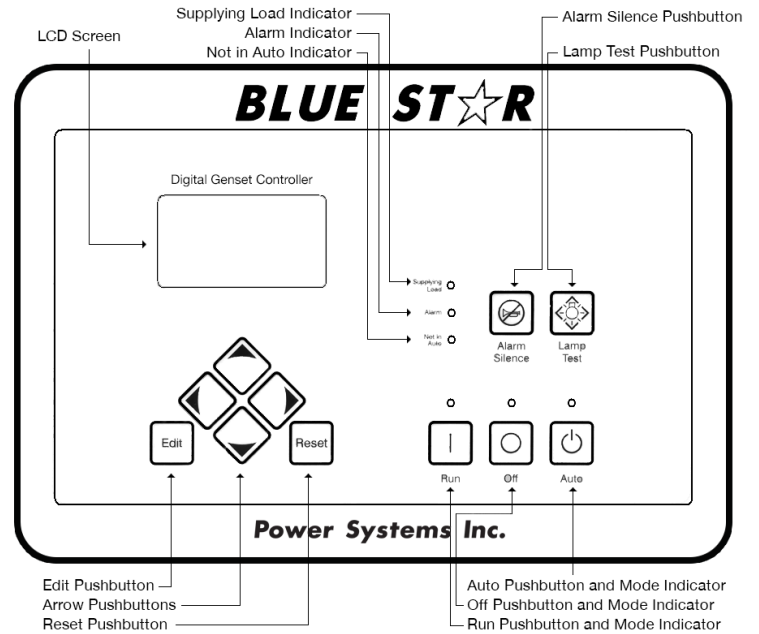

## Convenience Panel

- ▶ 2-50A 125/250VAC 3P4W Twist Lock Non-Nema CS6369
- ▶ 1-30A 125/250VAC 3P4W Twist Lock Nema L14-30R
- ▶ 2-20A 120VAC Duplex GFCI Nema 5-20R
- ▶ Thumb Screw Terminals for 2-Wire Remote Start
- ▶ 20A 240VAC Male Receptacle for Jacket Water Heater Shore Power Connection
- ▶ 15A 120VAC Male Receptacle for Battery Charger Shore Power Connection
- ▶ 13-400A Rated Female Cam Style Locking Receptacles for Load Connection

# Diesel Product Line

250 kWe / 250 kWe



## Dimensions

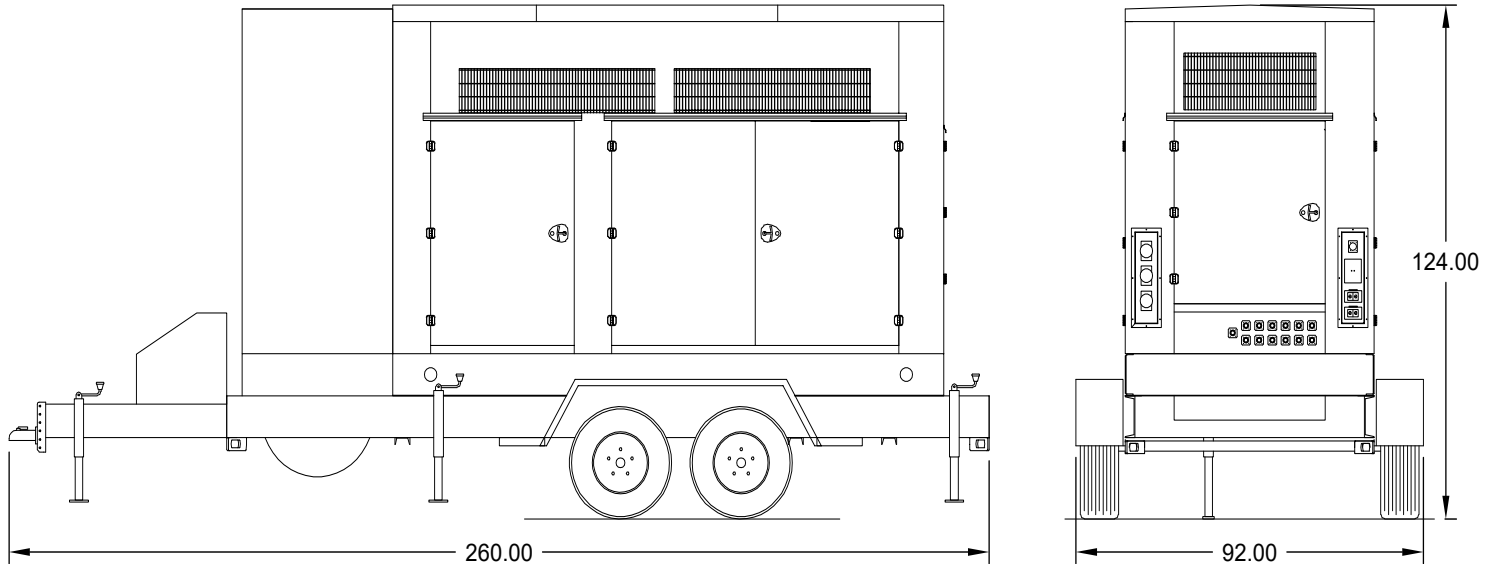

All specification sheet dimensions are represented in inches.  
All enclosures and fuel tanks are based on the standard standby unit configuration. Any deviation can change dimensions.  
Materials and specifications subject to change without notice.

American Owned



American Made

Distributed By:

**Blue Star Power Systems, Inc.**

2250 Carlson Drive  
North Mankato, Minnesota 56003  
Phone + 1 507 345 1776  
bluestarps.com  
quote.bluestarps.com  
sales@bluestarps.com